

TX-R3A140-005G

PRODUCT SPECIFICATION

Approved by: _____

Checked by: _____

Prepared by: _____

Part No.	TX-R3A140-005G	Spec No.	WKF-BA3001	Page	1 of 8
-----------------	----------------	-----------------	------------	-------------	--------

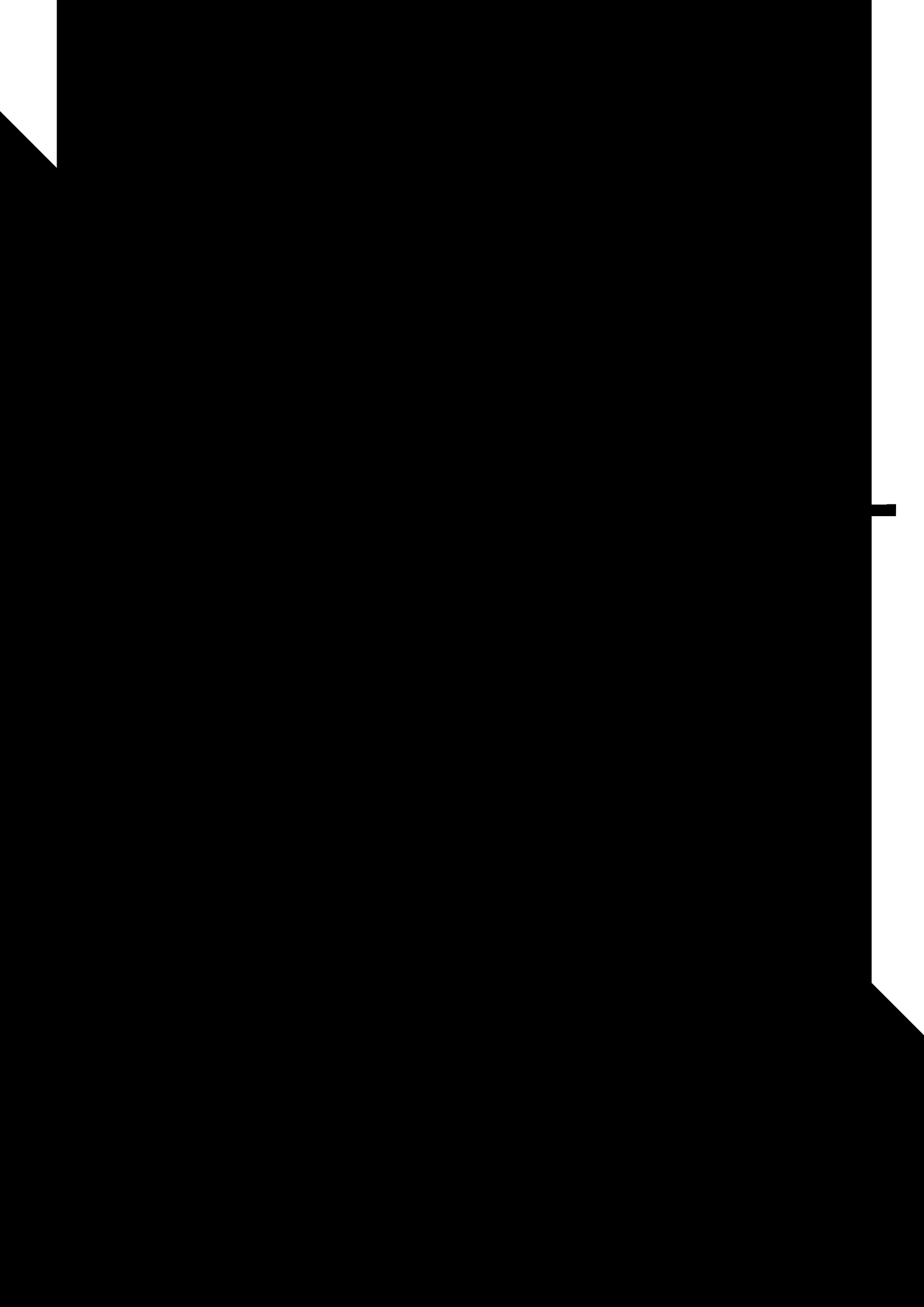

Notes:

- 1. All dimensions are in millimeters (inches).
- 2. Tolerance is ± 0.25 mm (0.01") unless otherwise noted.

Absolute Maximum

Spec

Part No.	TX-R3A140-005G	Spec No.	WKF-BA3001	Page	3 of 8
-----------------	----------------	-----------------	------------	-------------	--------

Characteristics at $I_f=700mA$, $V_r=5V$ ($T_a=25^\circ C$) \(

Parameter	Symbol	Values			Units
		Min.	Typ.	Max.	
Luminous Flux	ν	80	105	—	lm
Viewing Angle at 50%IV	$2\ 1/2$	—	140	—	Deg
Peak Emission Wavelength	λ_p	—	630	635	nm
Dominant Wavelength	λ_d	618	623	628	nm
Spectral Line Half-Width	$\Delta\lambda$	15	20	25	nm
Forward Voltage	V_f	2.0	2.6	3.2	V
Reverse Current	I_R	—	—	10	μA
Thermal Resistance Junction to Case	R_{J-C}	—	25	—	K/W
Temperature Coefficient of Forward Voltage	$V_f/F/T$	—	-2	—	mV/

Notes:

- Luminous intensity is measured with a light sensor and filter combination that approximates the CIE eye-response curve.
- $1/2$ is the off-axis angle at which the luminous intensity is 50% of the on-axis value.

Typical Electrical / Optical Characteristics Curves

(25 " Ambient Temperature Unless Otherwise Noted)

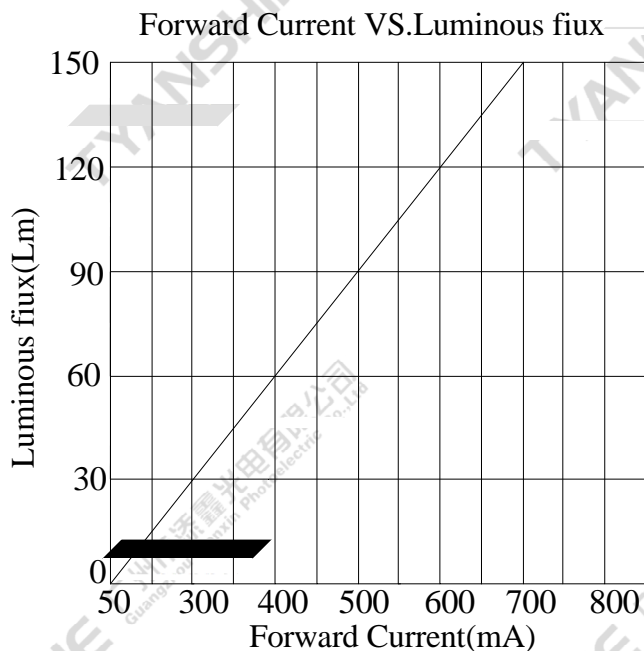
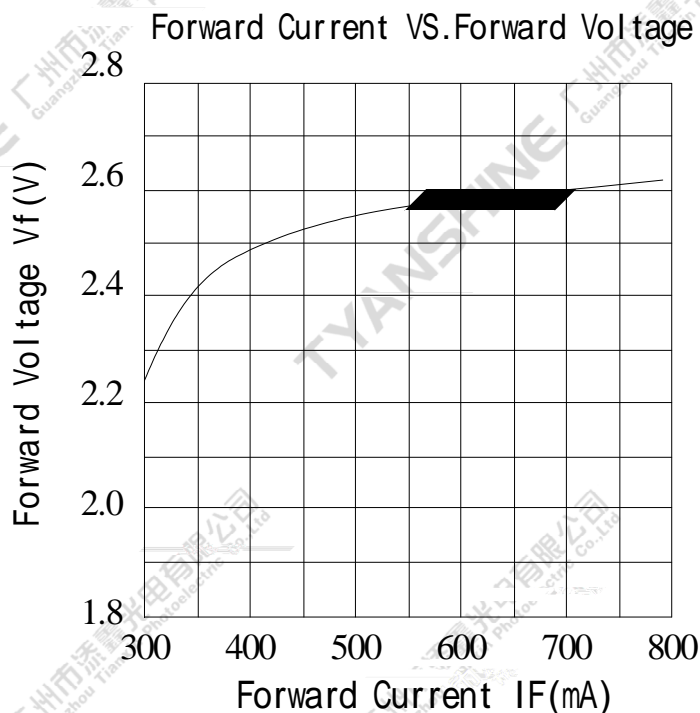

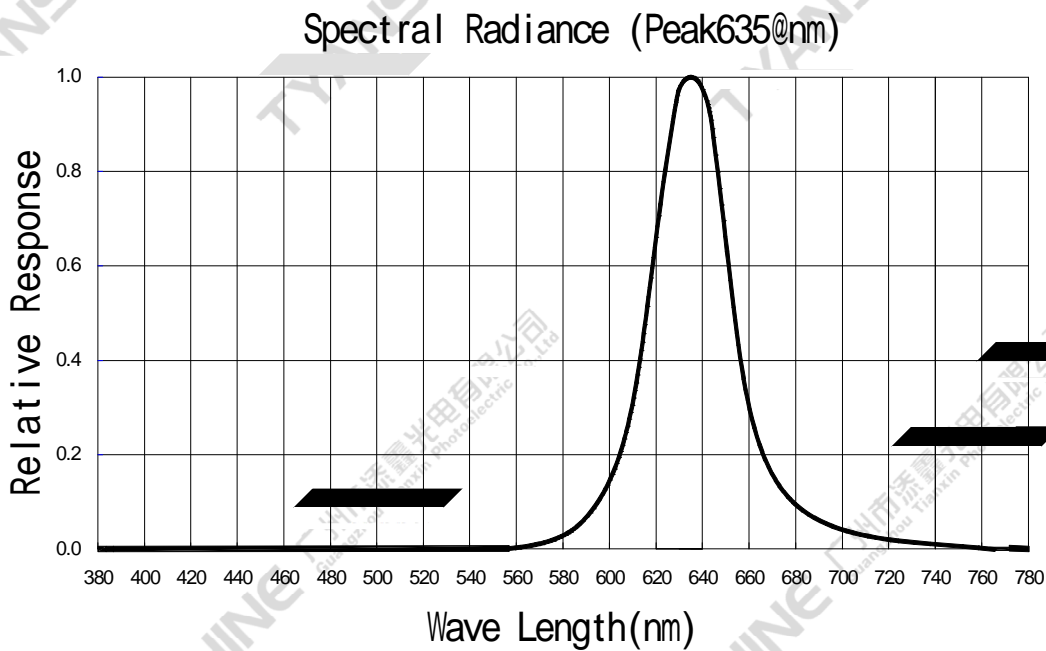
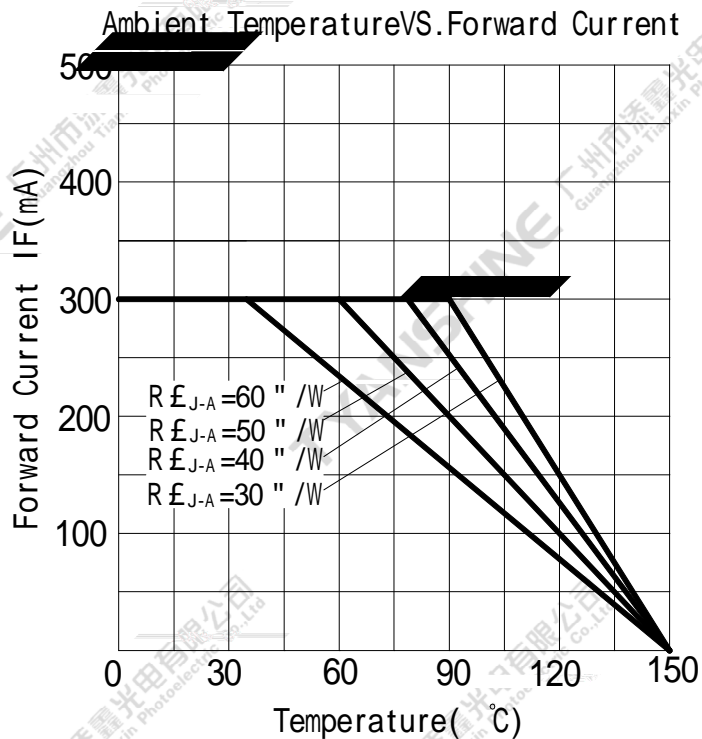

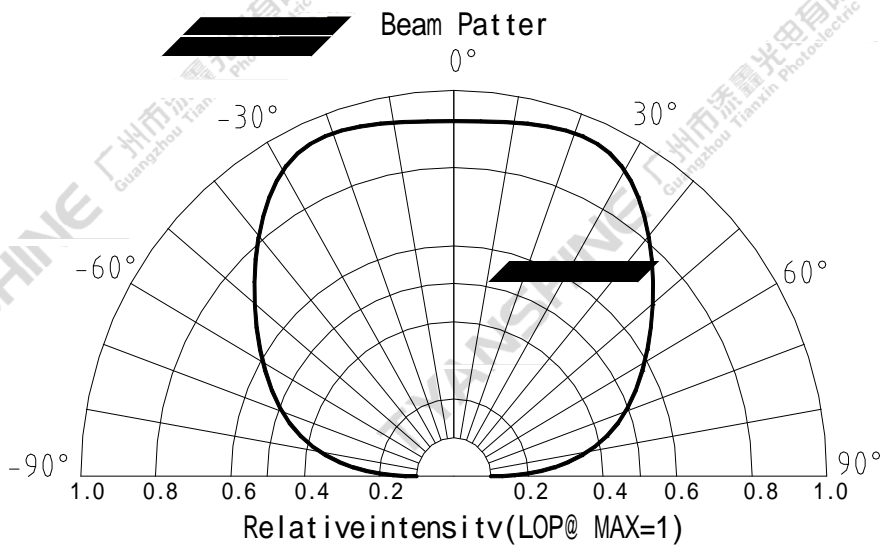

Notes:

- 1.2 1/2 is the off axis angle from lamp centerline where the luminous intensity is 1/2 of the peak value.
- 2.View angle tolerance is±5°.

Part No.	TX-R3A140-005G	Spec No.	WKF-BA3001	Page	7 of 8
----------	----------------	----------	------------	------	--------

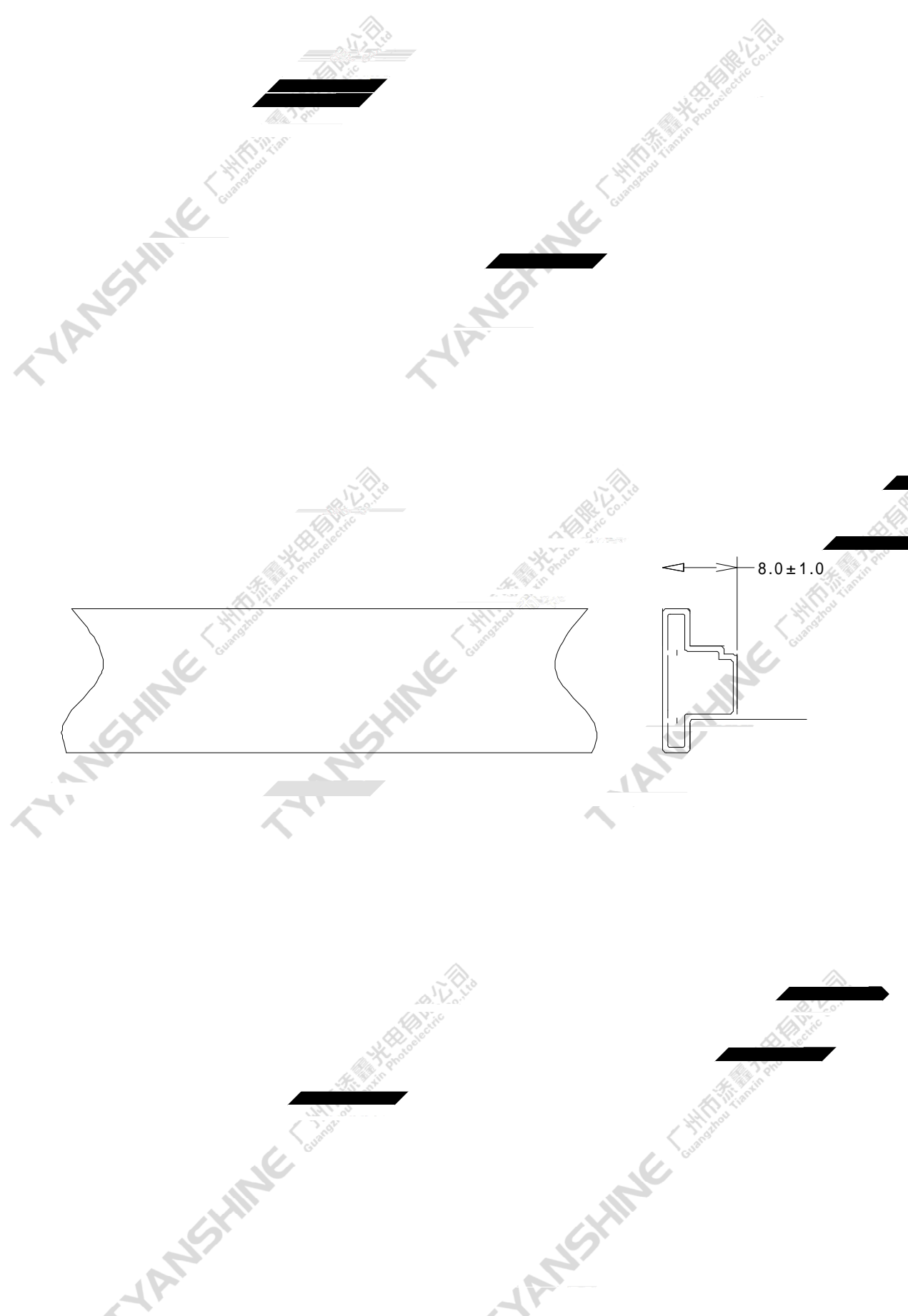

Part No.	TX-R3A140-005G	Spec No.	WKF-BA3001	Page	8 of 8
----------	----------------	----------	------------	------	--------